



Canyon County Horse Leaders'

Pattern Book

#2



SHOWMANSHIP
Patterns

Pattern Book

#2

- Novice
- &
- Advanced

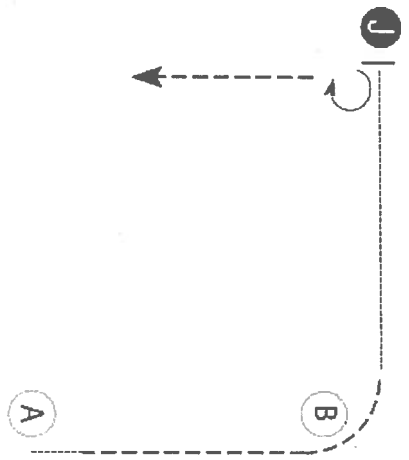

- Be ready at A.
1. Walk two steps/strides.
 2. Trot to and around B.
 3. Break to a walk and walk to the Judge.
 4. Stop and set-up for inspection.
 5. When excused, complete a 3/4 (270°) pivot and trot past A.

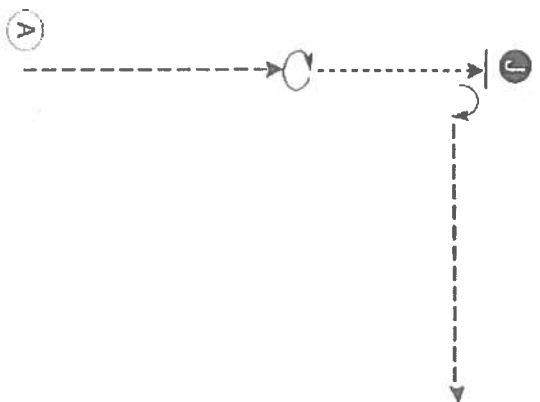
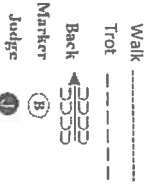

- Be ready at A.
1. Walk two steps/strides.
 2. Trot half way to the Judge.
 3. Stop and perform a full (360°) pivot/turn.
 4. Walk to the judge, stop and set-up for inspection.
 5. When dismissed, perform a 1/2 (90°) pivot/turn.
 6. Trot to the line-up and



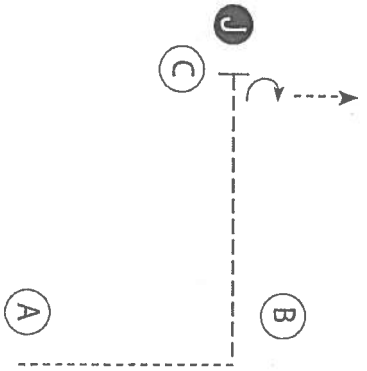

- Be ready at A.
1. Walk from A to B.
 2. Turn the corner just before B.
 3. Trot to C and to judge as shown.
 4. Stop and set up for inspection.
 5. When dismissed, perform a 90 degree turn and walk away.

Follow the instructions of your ring steward.

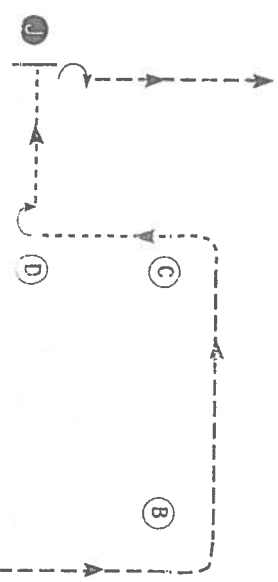
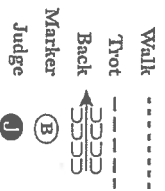

- Be ready at A.
1. Walk two steps/strides.
 2. Trot to and around B and to C.
 3. Break to a walk and walk around C to D.
 4. At D Complete a 1/2 (90°) pivot/turn.
 5. Walk to the Judge, stop and set-up for inspection.
 6. When dismissed, perform a 1/2 (90°) pivot/turn and trot away from judge
- Follow the ring steward's instructions



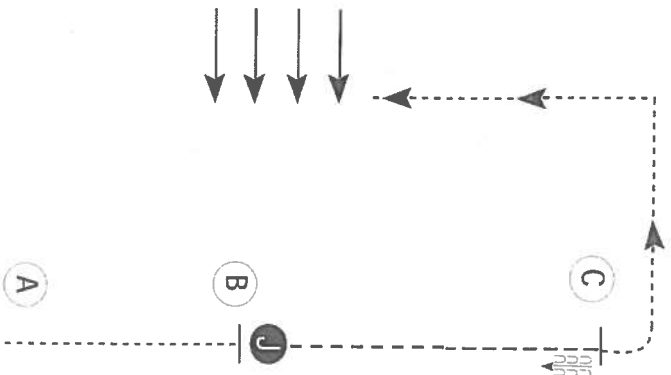

- Be ready at A.
1. Walk to the judge.
 2. Stop and set-up for inspection.
 3. When dismissed trot to C.
 4. Stop and back three (3) steps.
 5. Walk to line-up and set-up.

Follow the ring steward's instructions

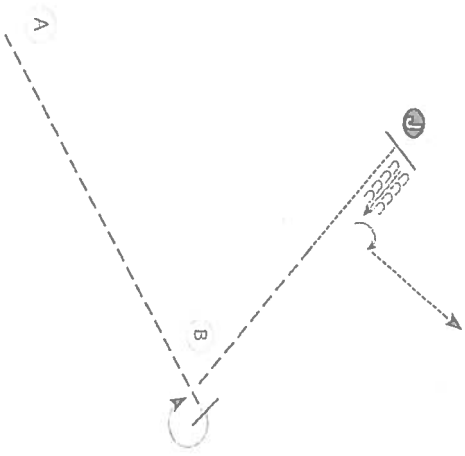

- Be ready at A.
1. Trot past B and stop.
 2. Perform a 1/2 (270°) pivot/turn.
 3. Trot halfway to the judge.
 4. Break to the walk and walk to the judge.
 5. Stop and set-up for inspection.
 6. When dismissed, back one horse length.
 7. Perform a 1/2 (90°) pivot/turn and walk away from judge to line up.

Follow the ring steward's instructions

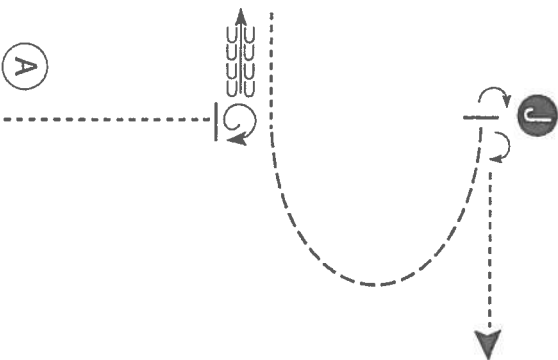

Be ready at A.

1. When acknowledged, walk half way to Judge.
2. Stop and perform a 1 ½ (450°) turn.
3. Back approximately one horse length.
4. Walk until even with Judge.
5. Trot in a half circle until even with Judge.
6. Perform a ¼ (90°) turn, stop and set-up for inspection.
7. When dismissed, complete a ¼ (90°) turn and walk straight away from Judge.

Follow the ring steward's instructions

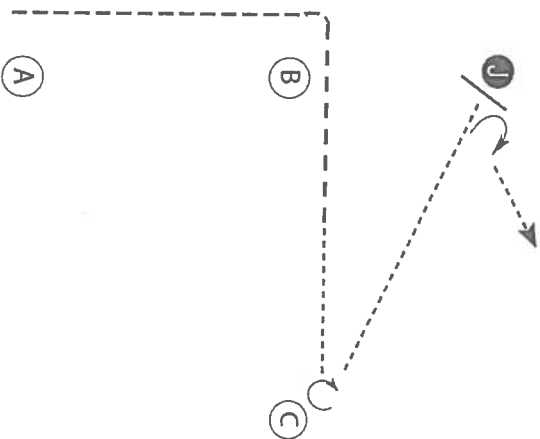
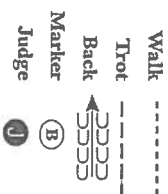

Be ready at A

1. Trot to and around B continue towards C
2. Halfway to C break to Walk and continue to C.
3. Stop at C.
4. Perform a 5/8 (225°) turn.
5. Walk to Judge and set-up for inspection.
6. When dismissed, complete a ¼ (90°) turn and walk to line-up.

Follow the ring steward's instructions

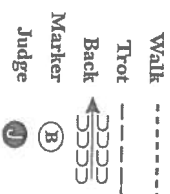

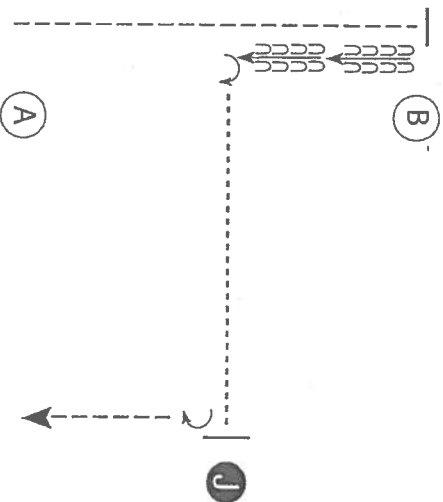

Be ready at A.

1. Trot to B and stop.
2. Back until even with Judge.
3. Perform a 90 degree turn. Walk to Judge.
4. Stop and set up for inspection.
5. When dismissed, perform a 90 degree turn.
6. Trot to the line up or follow the directions of the ring steward.

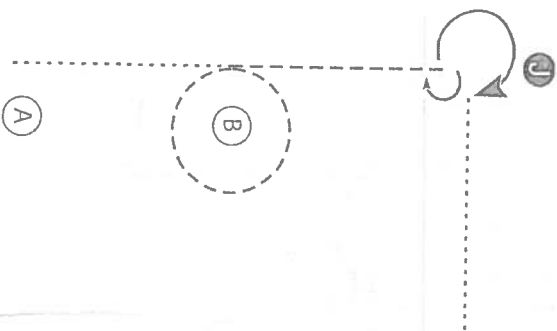
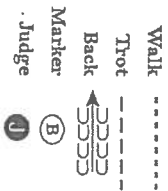

1. Walk from A to B.
2. At B trot. Trot a circle around B and continue to the Judge.
3. Stop and perform a 180 degree turn. Set up for inspection.
4. When dismissed perform a 270 degree turn.
5. Walk straight away from the Judge.



Follow the instructions of the ring steward.

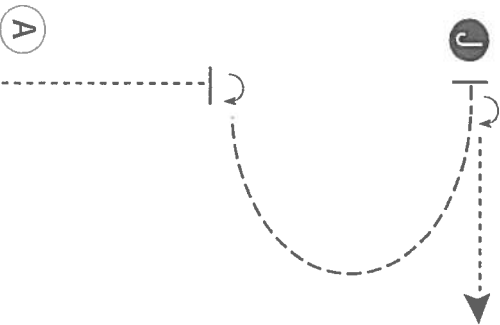

Be ready at A.

1. When acknowledged, walk half the distance to Judge.
2. Stop and perform a 1/4 turn.
3. Trot in a half circle to Judge.
4. Stop and set up for inspection.
5. When dismissed, perform a 1/2 turn and walk straight away from Judge.

Follow the instructions of your ring steward.

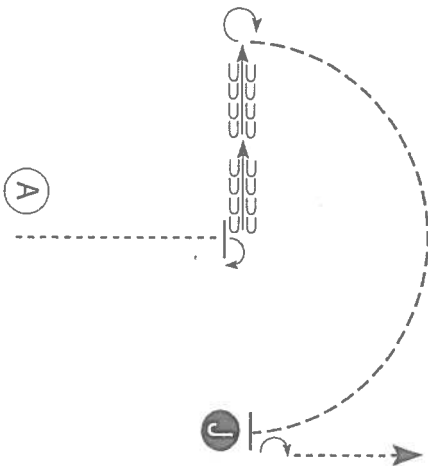
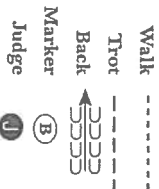

Be ready at A.

1. When acknowledged, walk until horse's hip is even with Judge.
2. Perform a 90 degree turn.
3. Back approximately two horse lengths.
4. Stop and perform a 270 degree turn.
5. Trot in a half circle to Judge.
6. Stop and set up for inspection.
7. When dismissed, perform a 180 degree turn and walk straight away from judge.

Follow the instructions of your ring steward.

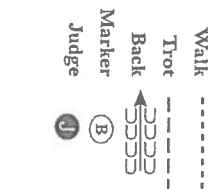

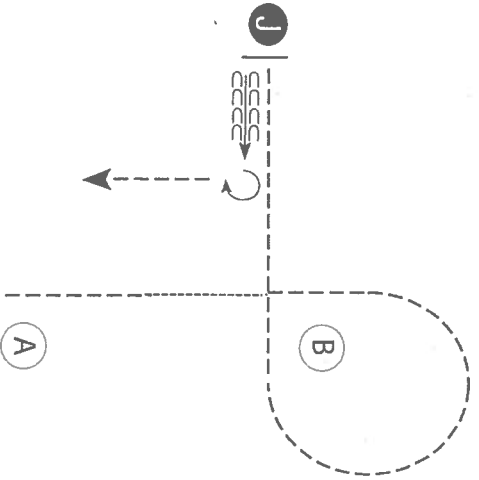

Be ready at A.

1. Trot halfway to B.
2. Walk two horse lengths.
3. Trot to and around B as shown.
4. Trot to the judge. Stop and set up for inspection.
5. When dismissed, back approximately 2 horse lengths.
6. Perform a 270 degree turn and trot straight away.

Follow the instructions of your ring steward.

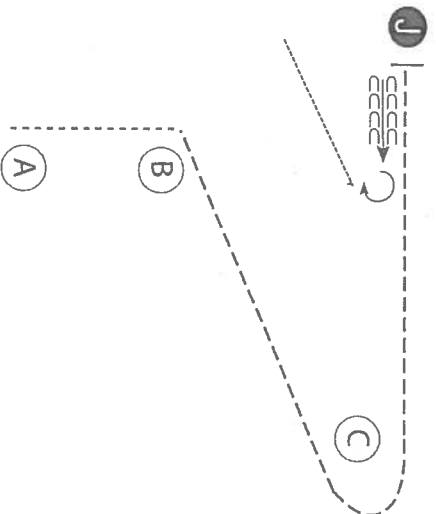
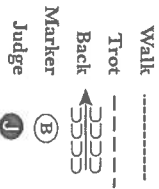

Be ready at A.

1. When acknowledged walk to B.
2. At B, Trot to and around C as diagramed
3. Trot to Judge.
4. Stop and set-up for inspection.
5. When dismissed, back approximately one horse length.
6. Perform a 7/8 (315°) turn and walk to line-up.

Follow the ring steward's instructions

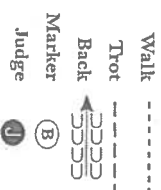

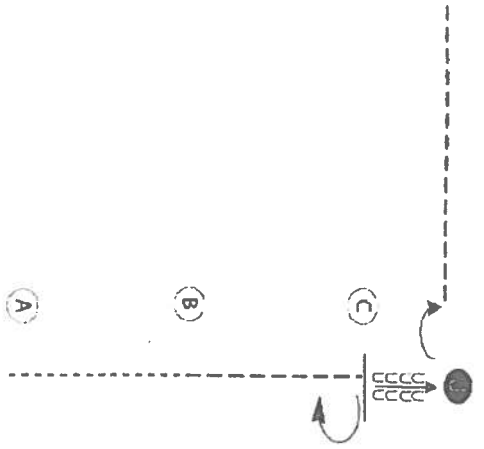

- Be ready at A.
1. Walk from A to B
 2. Trot B to C.
 3. Stop at C and perform a ½ (180°) turn.
 4. Back to Judge and set-up for inspection.
 5. When dismissed, perform a ¼ (90°) turn and trot straight away from Judge.

Follow the ring steward's instructions

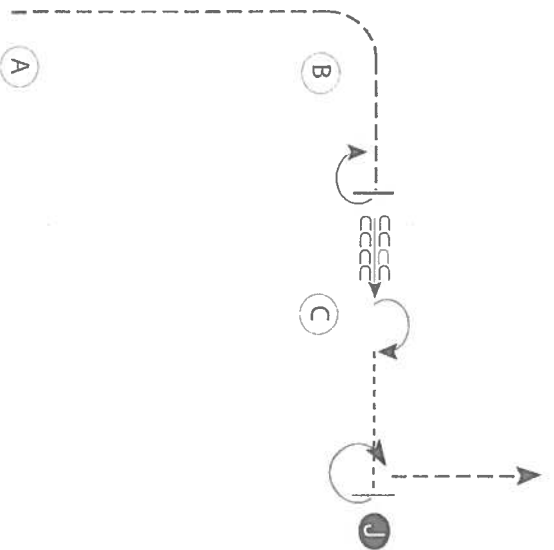

1. Jog from A around B
2. Half way to C stop and perform a 180 degree turn
3. Back to C
4. Perform a 180 degree turn, walk to Judge and set up for inspection
5. When dismissed perform a 270 degree turn and trot to lineup



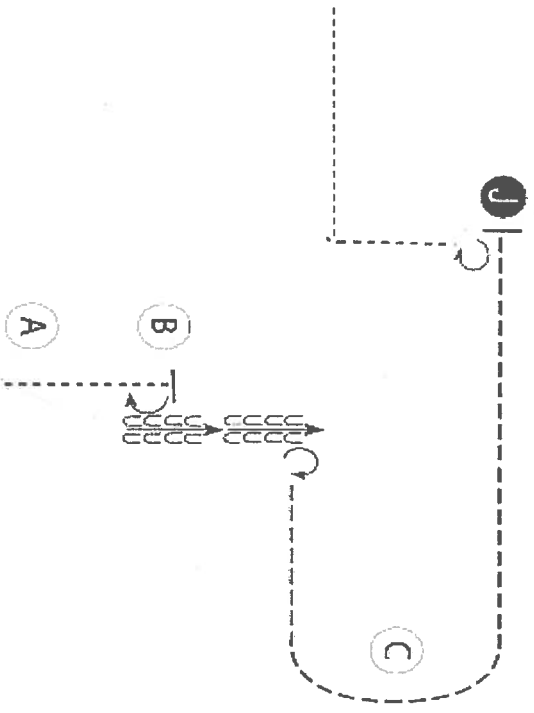

- Be ready at A.
1. Walk from A to B
 2. Perform a ½ (180°) turn at B.
 3. Back approximately 1.5 horse lengths.
 4. Perform a ¾ (270°) turn.
 5. Trot to and around C and continue to Judge.
 6. Stop and set-up for inspection.
 7. When dismissed, perform a ¾ (270°) turn
 8. Walk to line-up

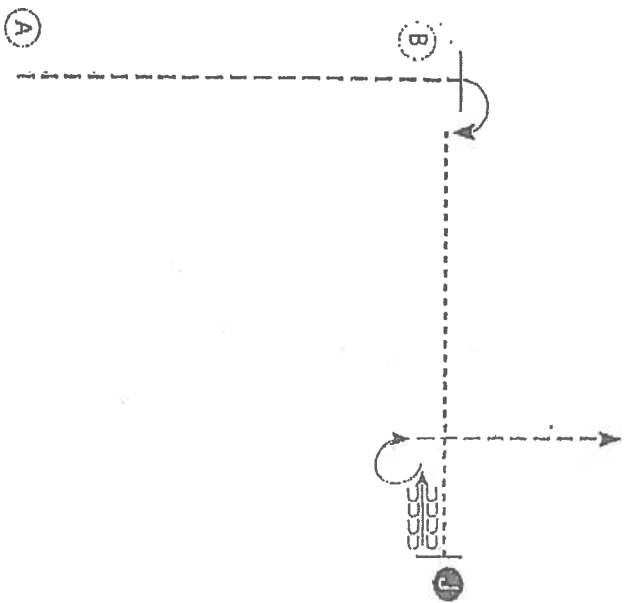

- Begin at A. Trot from A past B.
- Stop and perform a 90 degree turn
- Walk to the Judge, stop and set up for inspection
- When dismissed, back one horse length and perform a 270 Degree turn
- Trot to the line-up

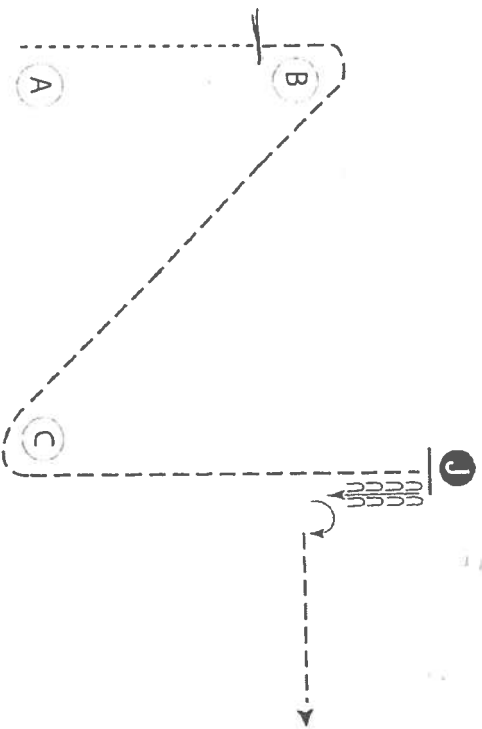

- Be ready at A.
1. Walk to B.
 2. Trot around B and straight to judge.
 3. Stop and set up for inspection.
 4. When dismissed, back one horse length.
 5. Perform a 90 degree turn.
 6. Trot straight away to finish.

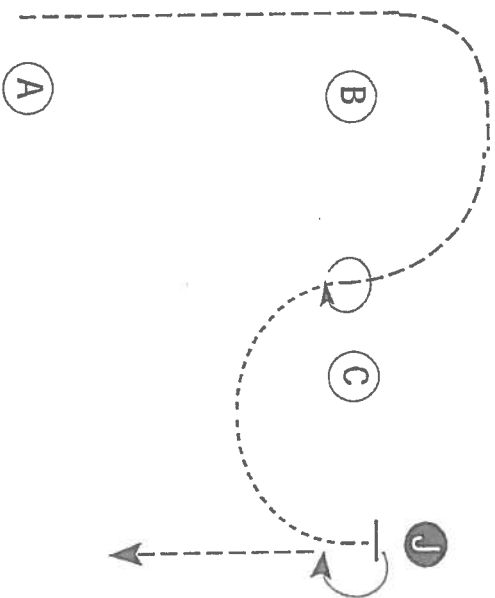
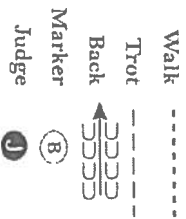

- Be ready at A.
1. Trot from A around B and to C.
 2. Stop and perform a 360 degree turn.
 3. Walk to the Judge. Stop and set up for inspection.
 4. When dismissed perform a 180 degree turn and trot straight away from the Judge.

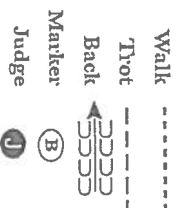

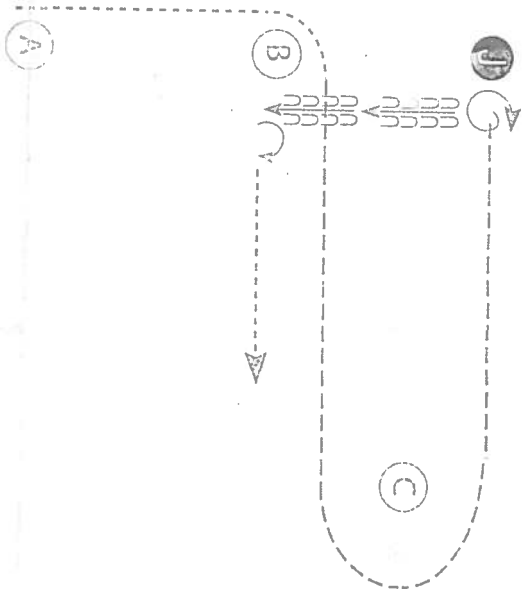

- Be ready at A.
1. Walk to and around B.
 2. Trot from B, around C and to judge.
 3. Stop and set up for inspection.
 4. When dismissed, perform a 1 1/4 turn.
 5. Back to B.
 6. Turn 1/4 turn and walk to exit.

Follow the instructions of your ring steward.

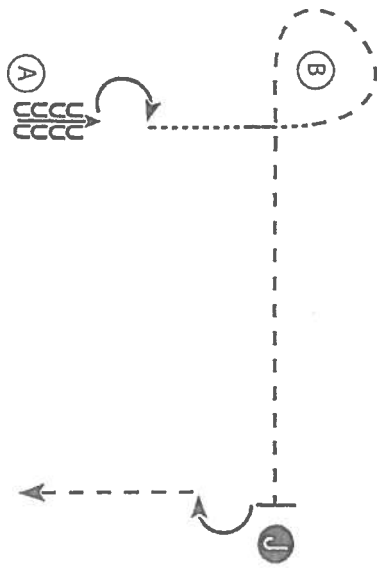
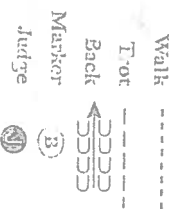

1. At A back 4 steps
2. Perform a 180 degree turn
3. Walk to B
4. At B trot around B and to the judge, set up for inspection
5. When dismissed perform a 90 degree turn and trot straight away from the judge



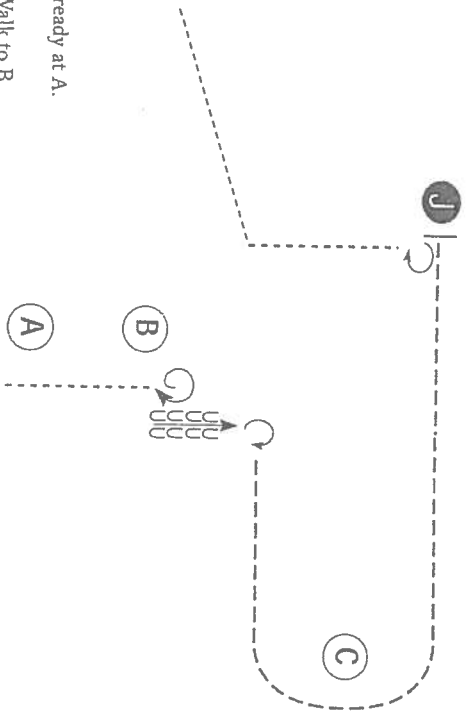

Be ready at A.

1. Walk to B.
2. Perform a 5/40 degree turn. (1 1/2 turn)
3. Back approximately one horse length.
4. Perform a 2/70 degree turn. (1 1/2 turn)
5. Trot around C and to judge.
6. Stop and set up for inspection.
7. When dismissed, perform a 2/70 degree turn.
8. Walk straight away from judge.

Follow the instructions of your ring steward.

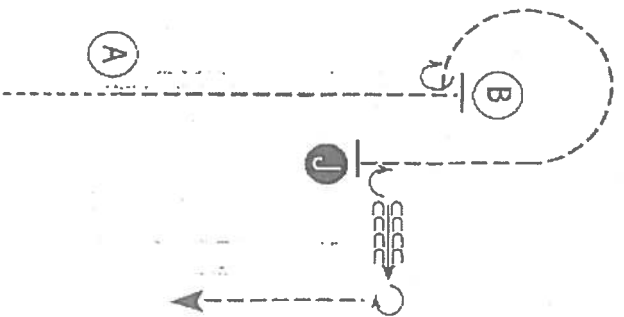
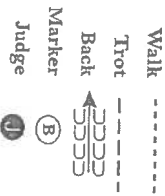

Be ready before A.

1. Walk to A.
2. Trot to B and stop.
3. Perform a 2/70 degree turn.
4. Trot around B and to the judge.
5. Stop and set up for inspection.
6. When dismissed, perform a 9/0 degree turn.
7. Back approximately one horse length.
8. Perform a 2/70 degree turn and trot to exit.

Follow the instructions of your ring steward.

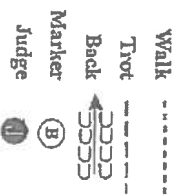

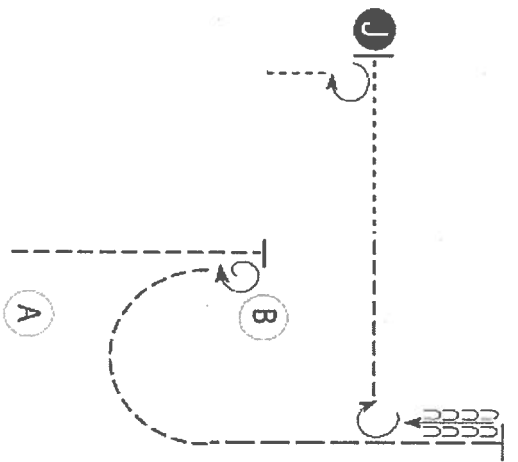

- Be ready at A.
1. Trot from A to B
 2. Stop Perform a 1 1/2 (540°) turn at B.
 3. Trot a half circle as shown
 4. Extend the trot in a straight line past Judge.
 5. Back until your horse's hip is even with Judge.
 6. Perform a 1/2 (270°) turn.
 7. Trot halfway to Judge then break to walk and continue to Judge.
 8. Stop and set-up for inspection.
 9. When dismissed, perform a 3/4 (270°) turn and walk straight away from judge.
 10. Walk to line-up following the ring steward's instruction.

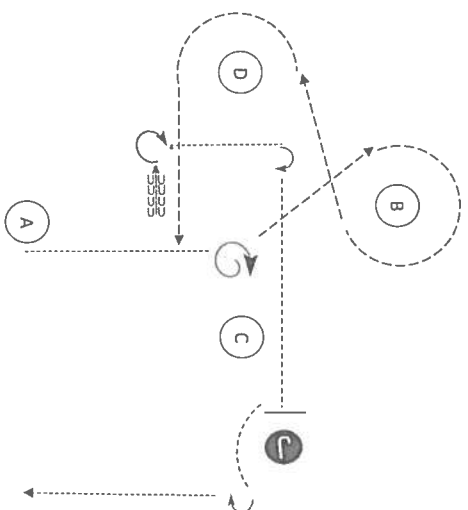

- Be ready at A.
1. Walk from A and stop with the horse's hind quarters centered between cones C & D
 2. Perform a 360° turn to the right on the hind quarters.
 3. Trot around cone B as shown
 4. Continue trotting around cone D as shown.
 5. Stop when the horse's nose is in line with cone A.
 6. Back five (5) steps
 7. Perform a 1/2 (270°) turn.
 8. Walk as diagramed until the hind quarters of the horse are in line with the Judge.
 9. Perform a 1/2 (90°) turn.
 10. Stop and set-up for inspection.
 11. When dismissed, push the horse slightly right, walk past judge, perform a 3/4 (90°) turn and trot away.
- Follow the ring steward's instructions



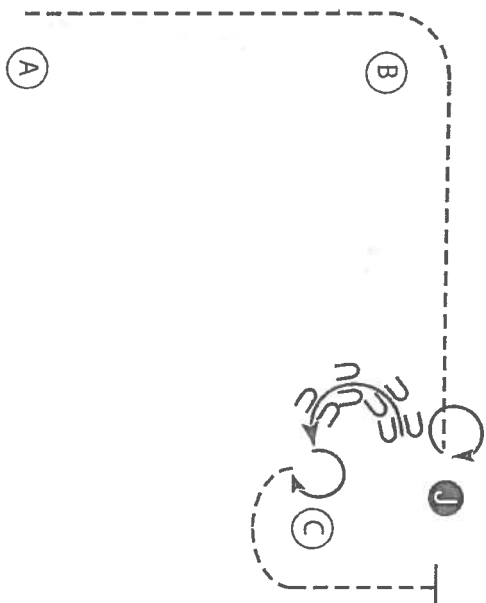

1. Trot from A to the Judge.
2. Stop and perform a 360 degree turn.
3. Set up for inspection.
4. When dismissed back a half circle to C.
5. Perform a 270 degree turn and trot until even with the Judge.
6. Stop and wait for instructions from the ring steward.

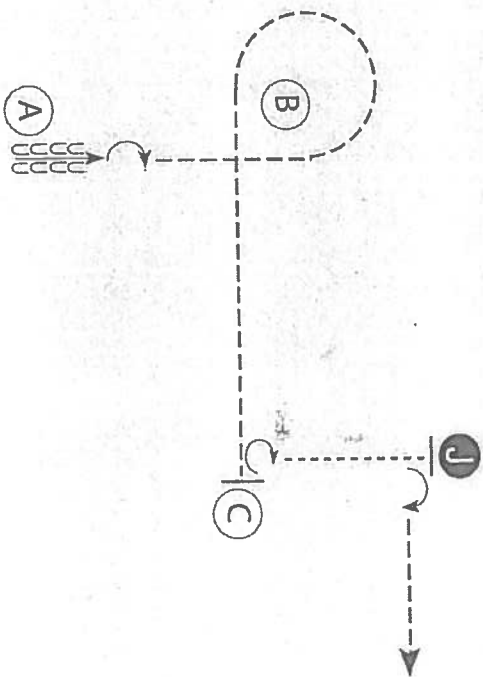

- Be ready at A.
1. When acknowledged, back 5 steps.
 2. Pivot 180 degrees.
 3. Trot to and around B and continue to C.
 4. Stop at C and turn 270 degrees.
 5. Walk to judge. Stop and set up for inspection.
 6. When dismissed, turn 90 degrees and trot away.
- Follow the instructions of your ring steward.

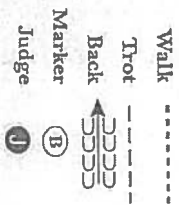

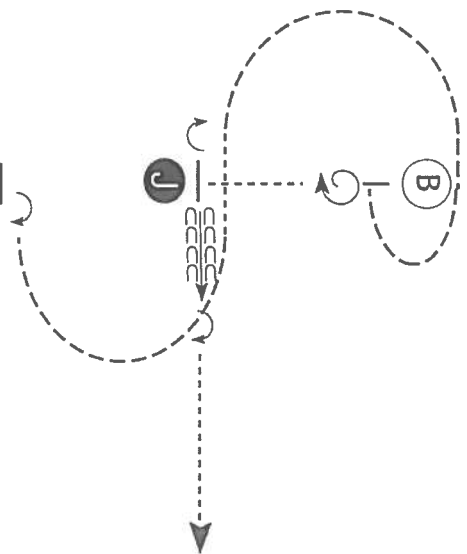

Be ready with your horse's tail at A.

1. Walk halfway to Judge.
2. Stop and perform a 1/4 turn.
3. Trot a half circle. Break to a walk before Judge and walk at least two horse lengths past Judge.
4. Trot a half circle to and around B as shown.
5. Stop and perform a 1 3/4 turn and walk to Judge.
6. Stop and set up for inspection.
7. When dismissed, perform a 1/4 turn.
8. Back approximately one horse length.
9. Perform a 1/2 turn and walk straight away to exit.

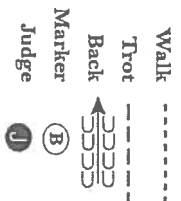

Follow the instructions of your ring steward.

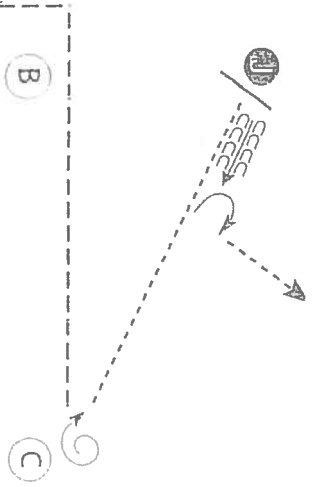

Be ready at A.

1. Trot to B.
2. Trot the corner at B and continue to trot to C.
3. Stop at C.
4. 1 5/8 turn at C.
5. Walk to judge and set up for inspection.
6. When dismissed, back one horse length.
7. 1/4 turn and walk off.

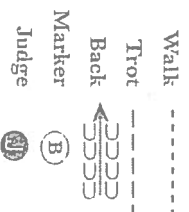



Western Horsemanship Patterns

Pattern Book

#2

- Walk Trot only patterns
 - Multiple levels of difficulty
- Walk Trot Lope patterns
 - Multiple levels of difficulty

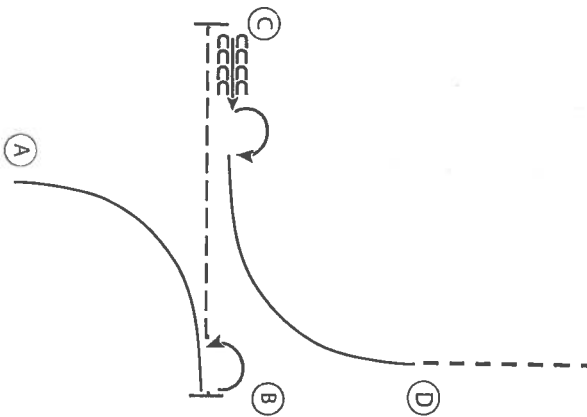

- Be Ready at A
1. Lope right lead in quarter circle to B
 2. Stop at B
 3. Perform a 180 degree haunch turn to the left
 4. Extended jog to C
 5. Stop at C and back four (4) steps
 6. Perform a 180 degree haunch turn to the right
 7. Lope left lead in quarter circle to D and break to jog--jog to line up

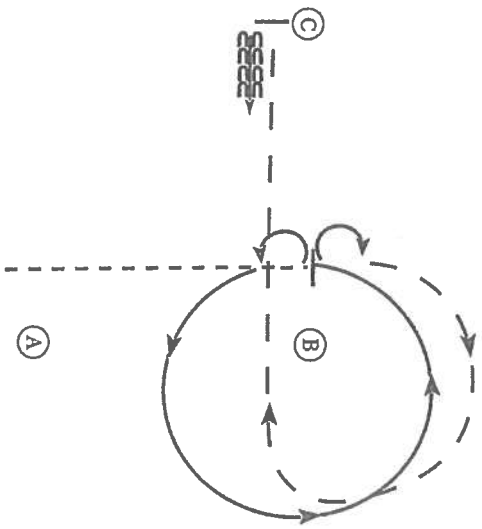
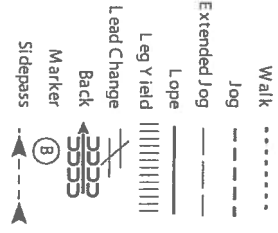

1. Jog A to B
2. Stop at B and perform a 180 degree turn to the left
3. Lope a circle around B on the left lead
4. Stop at B and perform a 180 degree turn to the right
5. Extend the jog in a circle around B and continue to C
6. Stop at C and back approximately one horse length.

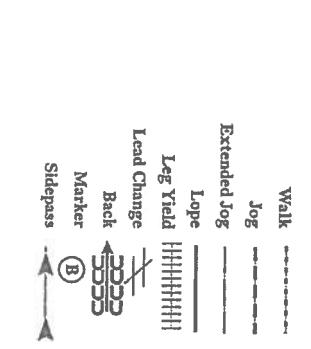

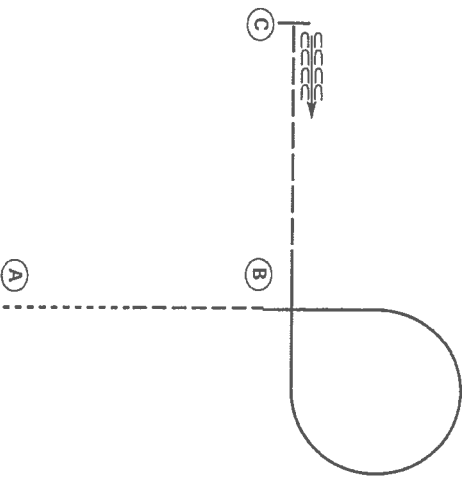

- Be ready at A.
1. Walk from A 1/2 way to B.
 2. Jog the rest of the way to B.
 3. Lope a circle to the right, on the right lead
 4. Perform an extended jog from B to C.
 5. Stop at C and back one horse length.

Follow the instructions of your ring steward

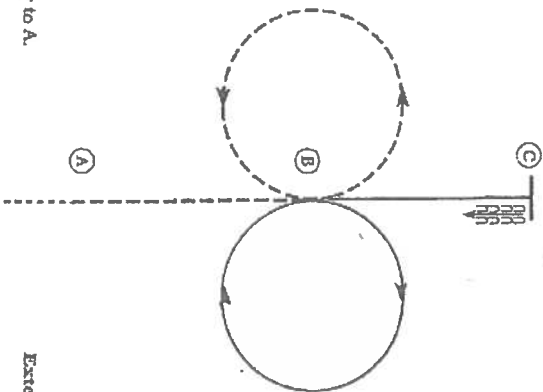
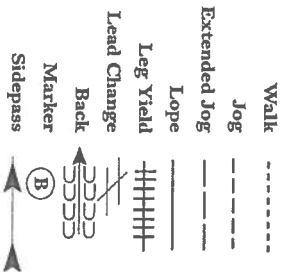

- Be ready prior to A.
1. Walk to A.
 2. Jog A to B.
 3. At B jog a circle to the left.
 4. At B lope a circle to the right on the right lead.
 5. Continue the lope to C.
 6. Stop at C and back approximately one horse length.

Follow the instructions of the ring steward

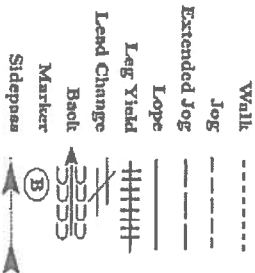

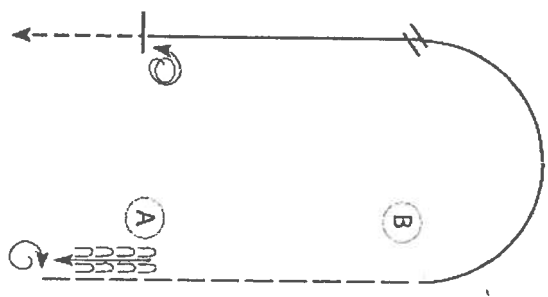

- Be Ready at A**
1. When acknowledged, back approx. two (2) horse lengths
 2. Perform a 360 degree haunch turn to the right
 3. Extend the jog to B
 4. Lope left lead in half circle until even with B
 5. Perform a lead change (simple or flying)
 6. Lope on right lead until even with A
 7. Stop and perform a 360 degree haunch turn to the right.
 8. Jog to line up and

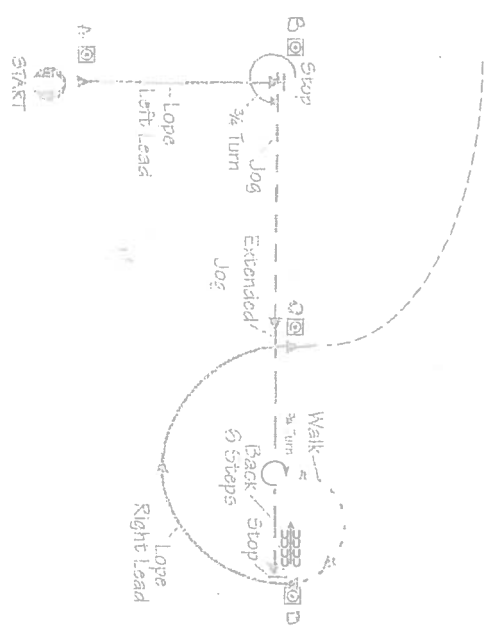
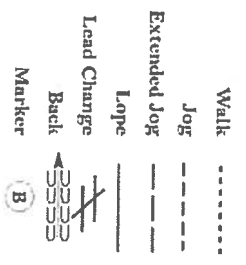

- Be Ready at A**
1. When acknowledged by Judge, Lope left lead to B
 2. Stop and perform a 3/4 turn (270°) left on hindquarters
 3. Jog to C and Extend the jog to D
 4. Stop and back six (6) steps
 5. Perform a 270 degree haunch turn to the right
 6. Walk a half circle to D.
 7. At cone D, lope a half circle to Con right lead
 8. Break to jog until even with B
 9. Jog to line up

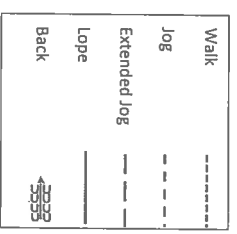

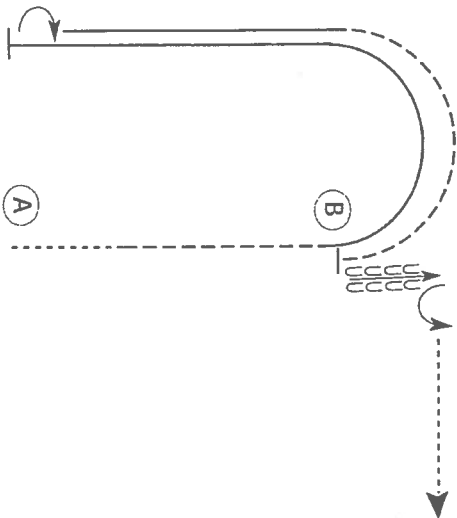

- Be ready at A.
1. Walk approximately 2 horse lengths from A.
 2. Jog to B.
 3. Lope on the left lead in a half circle and then straight until even with A.
 4. Stop and perform a 180 degree turn to the right.
 5. Lope on the right lead until even with B.
 6. Jog to B.
 7. Stop at B and back approximately one horse length.
 8. Perform a 90 degree turn to the left and walk straight away.

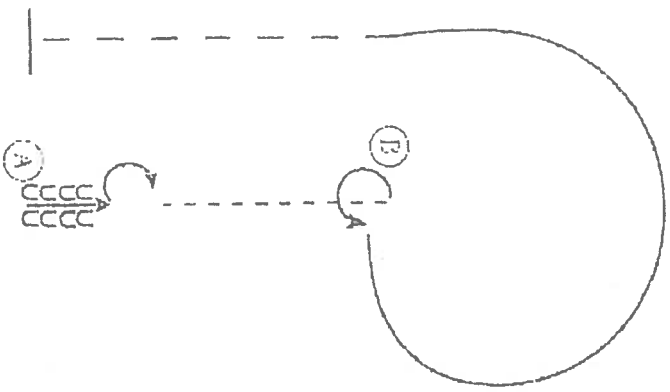
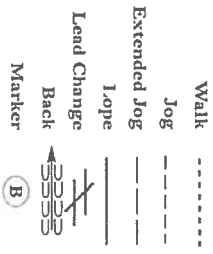

- Be Ready at A as shown
1. Back four (4) steps.
 2. Perform a 180 degree turn to the right.
 3. Jog to B.
 4. Stop at B and perform a 270 degree turn to the left.
 5. Lope a circle around B on the left lead as shown
 6. At B, break to an extended jog and continue to A.
 7. Stop at A.

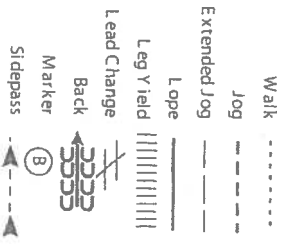

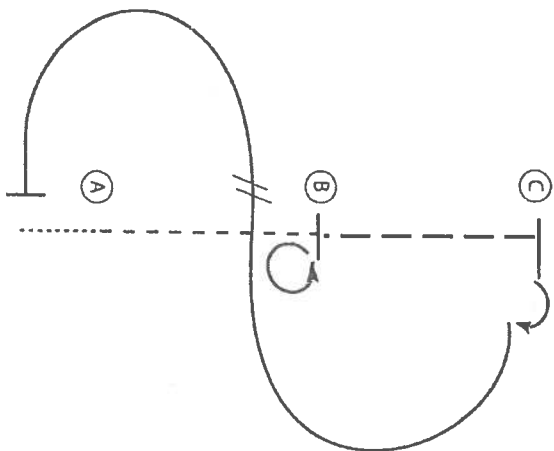

- Be ready BEFORE A
1. Walk to A
 2. Jog A to B
 3. Stop at B and perform a 360 degree turn to the left.
 4. Extended Jog from B to C
 5. Stop at C and perform a 90 degree turn to the right.
 6. Lope a half circle to B on the Right lead.
 7. At B perform a lead change (simple or flying) and lope a half circle to A on the left lead as shown.
 8. Stop at A.

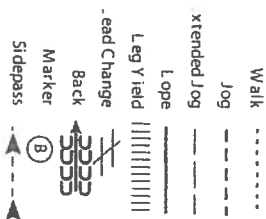

Follow the instructions of your ring steward.

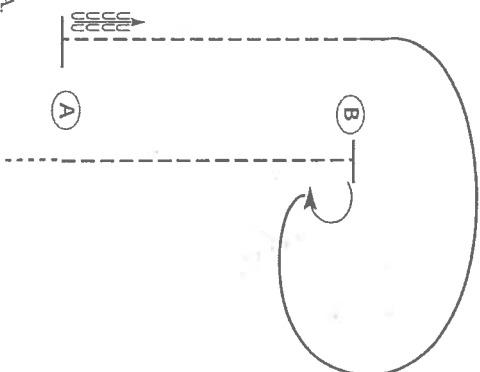

- Be ready before A.
1. Walk to A.
 2. Jog to B.
 3. Turn 180 degrees to the right.
 4. Lope on the left lead back around to B.
 5. Jog from B to A.
 6. Stop at A and back approximately one horse length.

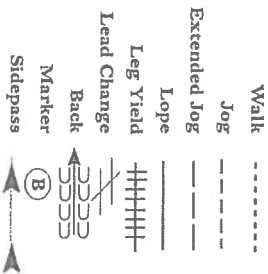

Follow the instructions of your ring steward.

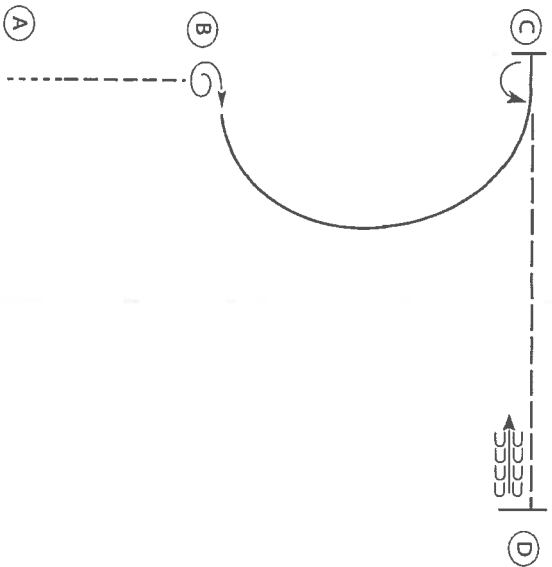

- Be ready at A
1. Walk to four (4) steps from A
 2. Jog to B
 3. At B, Stop and perform a 1 1/2 turn (450 degrees) to the right on the hindquarters.
 4. Lope a half circle on the left lead to C.
 5. At C stop and perform a 180 degree turn to the left on the hindquarters.
 6. Extend the jog to D
 7. Stop at D and back four (4) steps.

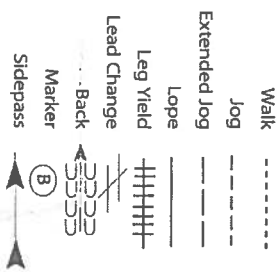

Follow the instructions of your ring steward.

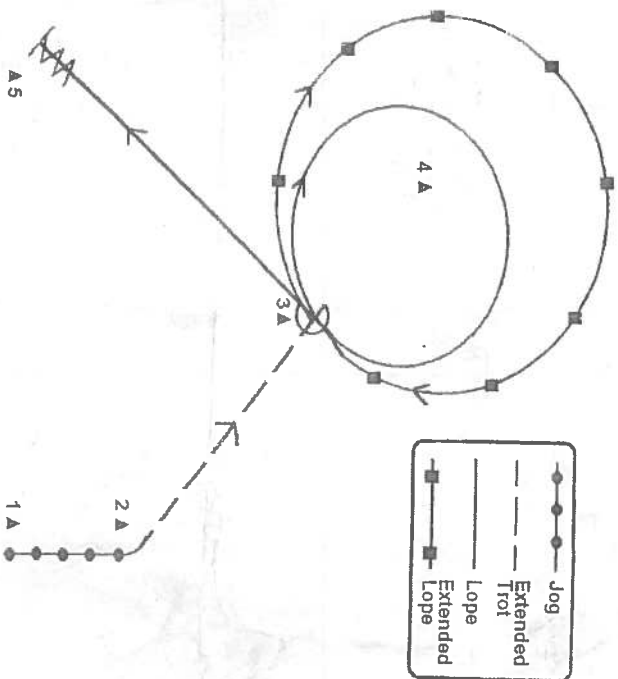

- Start at marker 1 and jog to marker 2. Extend the trot from marker 2 past marker 3. Stop and perform a 270 right turn. Depart into the right lead and extend the lope in a circle around marker 4. Close large circle and slow to a lope in a small circle. Close small circle and perform a simple or flying lead change at marker 3. Lope in the left lead to marker 5. Stop and back one horse length.

Follow the instructions of your ring steward

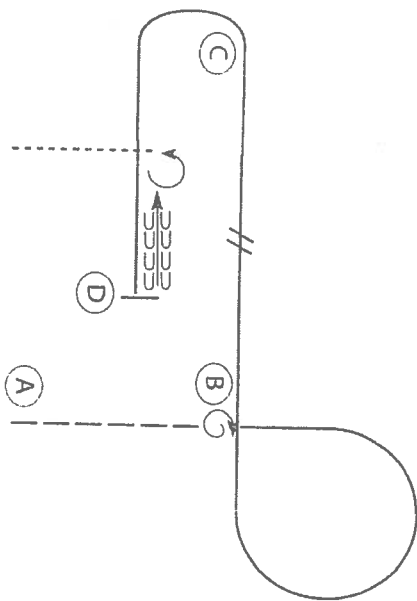

1. Extend the jog from A to B.
2. Stop at B and complete a 360 degree turn to the right.
3. Lope a large fast circle to the right.
4. At B, slow to a lope.
5. Halfway between B and C, change leads.
6. Lope on the left lead to D.
7. Stop at D and back approximately one horse length.
8. Turn ¼ (270 degree) turn to the left and walk to line up

Follow the instructions of your ring steward.

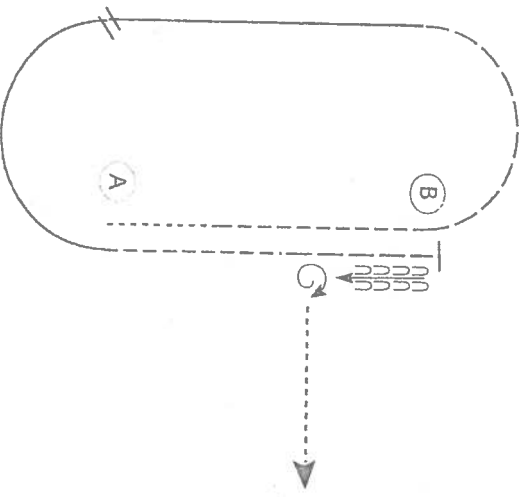
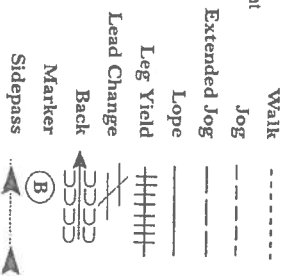

1. Walk approximately 2 horse lengths from A.
2. Jog to B.
3. Extend the jog in a half circle.
4. Lope on the right lead until even with A.
5. Perform a simple lead change.
6. Lope on the left lead until even with A.
7. Jog halfway to B.
8. Extend the jog to B.
9. Stop at B and back approximately one horse length.
10. Perform a 1 1/4 turn to the right and walk straight away.

Follow the instructions of your ring steward

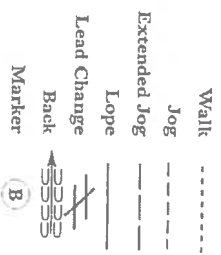

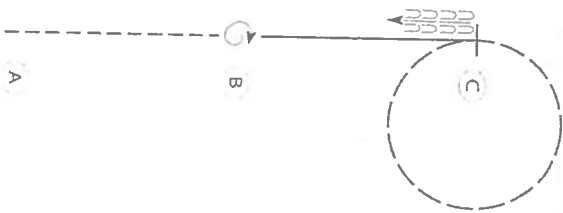

- Be ready at A
1. Jog from A to B.
 2. Stop at B and perform a 360 degree turn to the right.
 3. Lope on the right lead to C.
 4. Even with C, break to an extended jog and circle to the right.
 5. Stop at C and back one horse length.

Follow the instructions of your ring steward

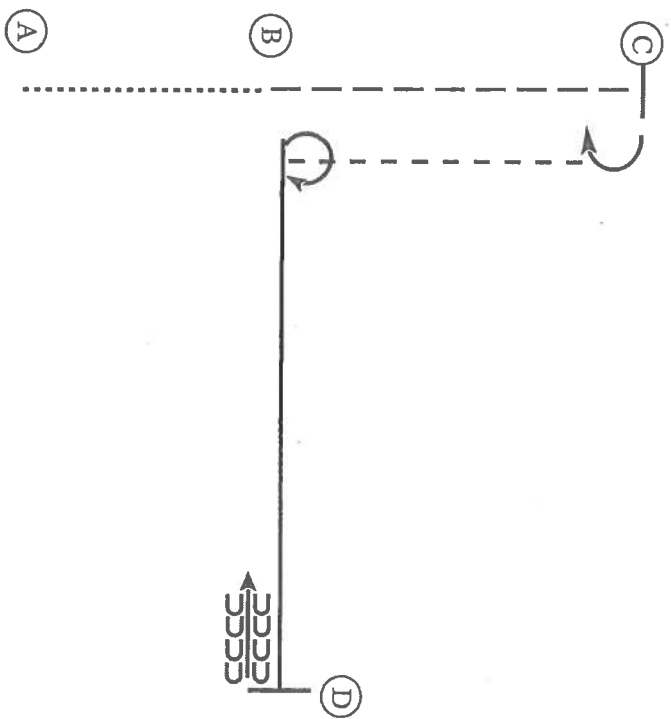
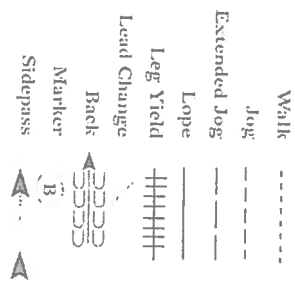

- Be Ready at A
1. Walk to A to B
 2. At B-- Extended Jog to C
 3. Stop at C and perform a 180 degree turn on the hindquarters to the right.
 4. Jog to B and stop.
 5. At B perform a 270 degree turn on the hindquarters to the right.
 6. Lope on the left lead to D.
 7. Stop at D and back six (6) steps.

Follow the instructions of your ring steward.

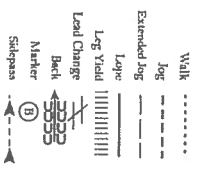

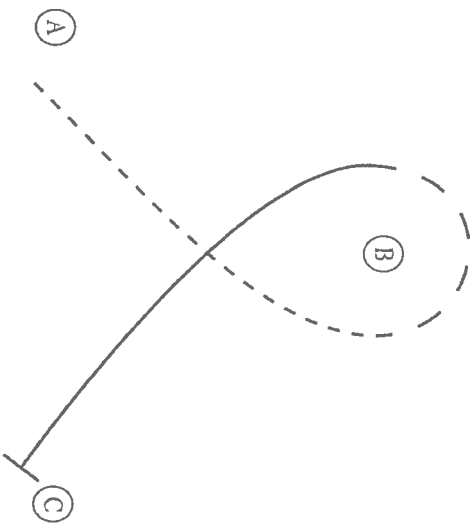

1. Jog A to B
2. At B extend the jog
3. Extended jog around B
4. At B lope on the left lead to C
5. Stop at C

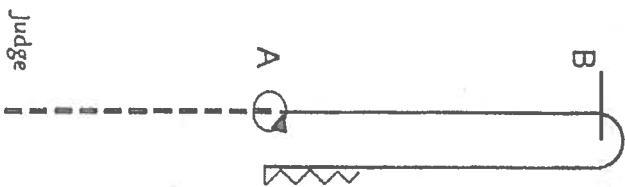
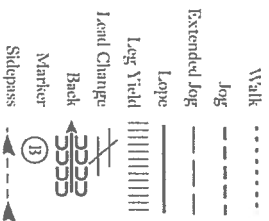

1. Be ready and in position to begin your pattern
2. Jog to marker "A"
3. Halt and 360° Left
4. Lope Left Lead to marker "B"
5. Halt and Roll Back to Right 180°
6. Lope Right Lead until even with marker "A"
7. Halt and back

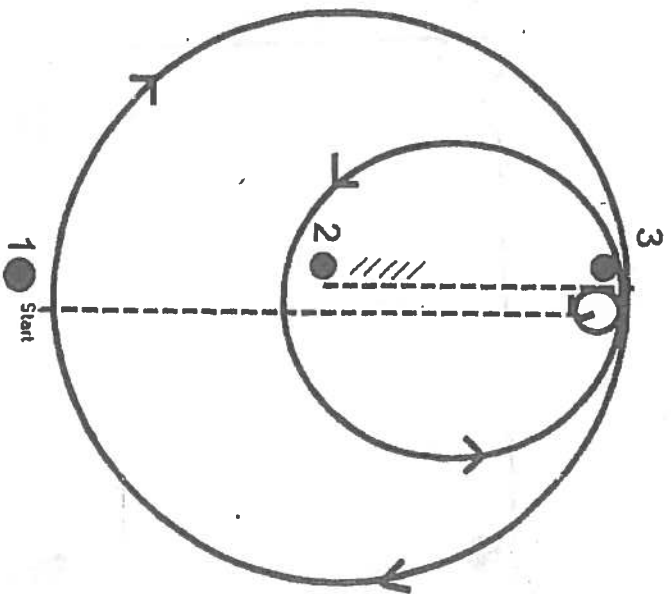

1. Extend trot to third marker.
2. Stop, do 1/4 turn to left.
3. Lope immediately off on left lead
4. Do small slow circle to left.
5. Stop even with top of third marker
6. Do 180 degree right turn.
7. Lope immediately off on right lead, lope fast circle to right.
8. When even at top of third marker, break to jog.
9. Jog to second marker
10. Stop and back.

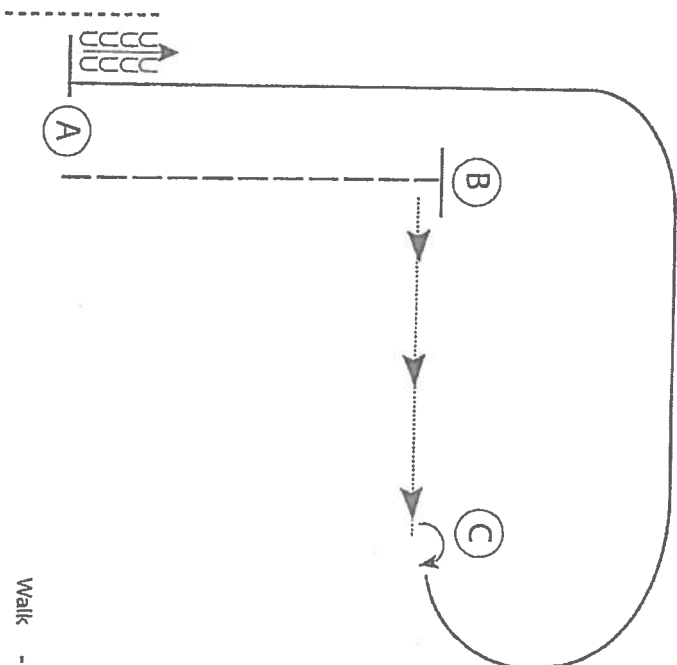

1. Extend the jog from A to B.
2. Stop at B and sidepass to C.
3. Perform a 90 degree turn to the right on the hindquarters. Lope left lead around B to A.
4. Stop and back three steps.
5. Walk to the line-up.

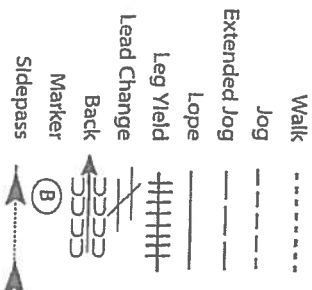

WALK / TROT / LOPE PATTERN (DO NOT use for Novice I, Walk Trot LTD I & II)

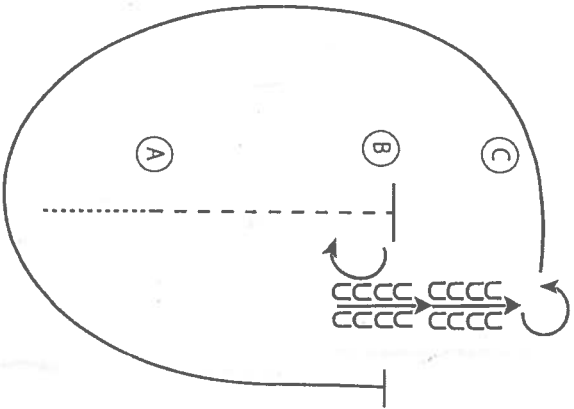

1. Walk to A
2. Jog A to B
3. Stop at B and perform a 180 degree turn to the right
4. Back to C
5. At C perform a 270 degree turn to the left
6. Lope a circle around A, returning to B on the left lead
7. Stop at B

Follow the instructions of your ring steward

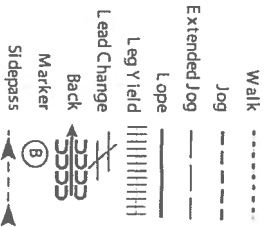

WALK / TROT / LOPE PATTERN (DO NOT use for Novice I, Walk Trot LTD I & II)

- Walk from cone 1 to cone 2
- Lope left lead from cone 2 to cone 3.
- Roll back right at cone 3.
- Lope right lead away from cone 3 turn and lope to cone 4.
- Stop at cone 4 and back one horse length.
- Jog from cone 4 to cone 5.
- Stop
- Pivot 180 degrees left.

Follow the instructions of your ring steward

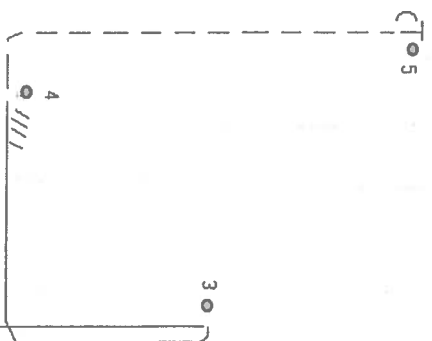
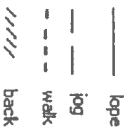

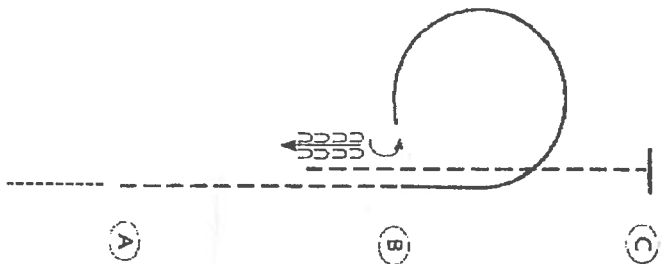

- Begin before A at a walk.
1. Jog from A to B
 2. At B, lope on the left lead and circle at B
 3. Turn 1/4 turn to the left.
 4. Back one horse length
 5. Jog to C. Stop at C.

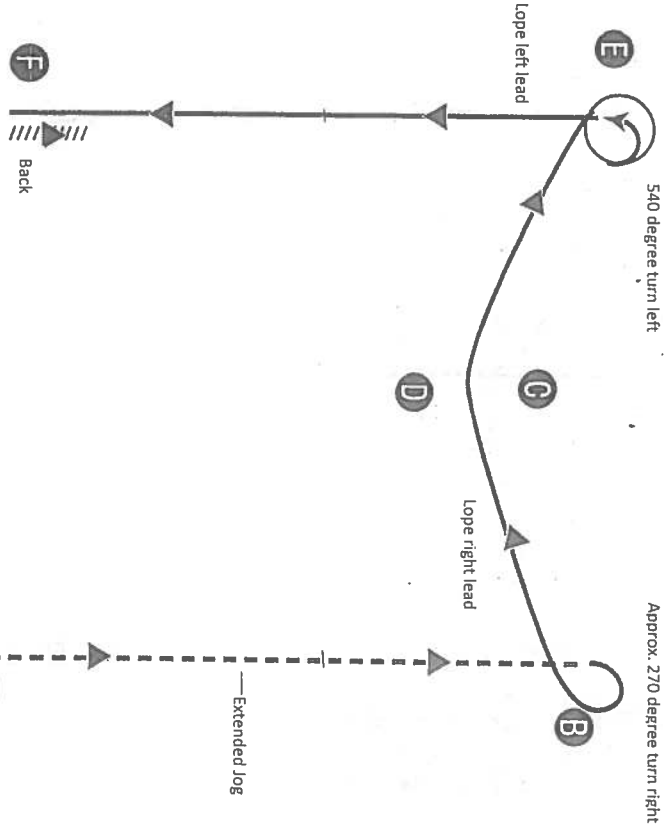
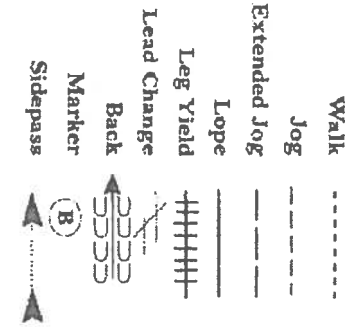

1. Start at marker A
2. Extended jog to marker B
3. Do approximately 270° turn to right on haunches and lope on right lead in between markers C & D and continue to marker E
4. Stop at marker E
5. Do a 1 1/2 turn (540°) to the left
6. Lope on left lead to marker F
7. Stop and back at least five steps

Follow the instructions of your ring steward.

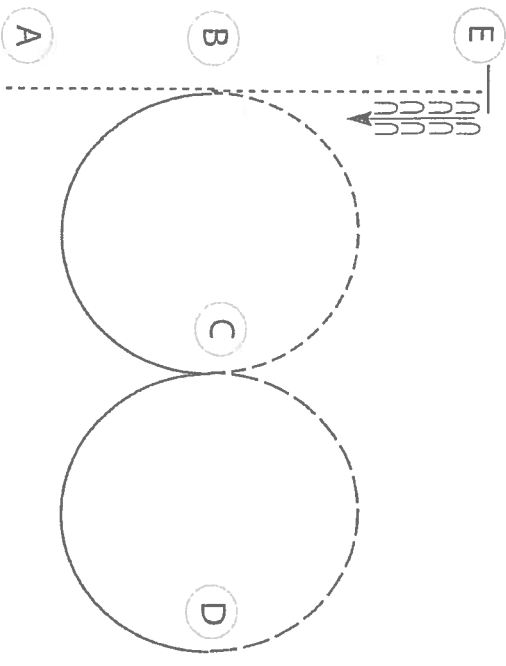

- Be ready at A.
1. Walk A to B.
 2. Jog a half circle to C.
 3. Lope a half circle on the left lead to D.
 4. Extend the jog in a half circle to C.
 5. Lope a half circle on the right lead to B.
 6. Walk to E.
 7. Stop at E and back approximately one horse length.

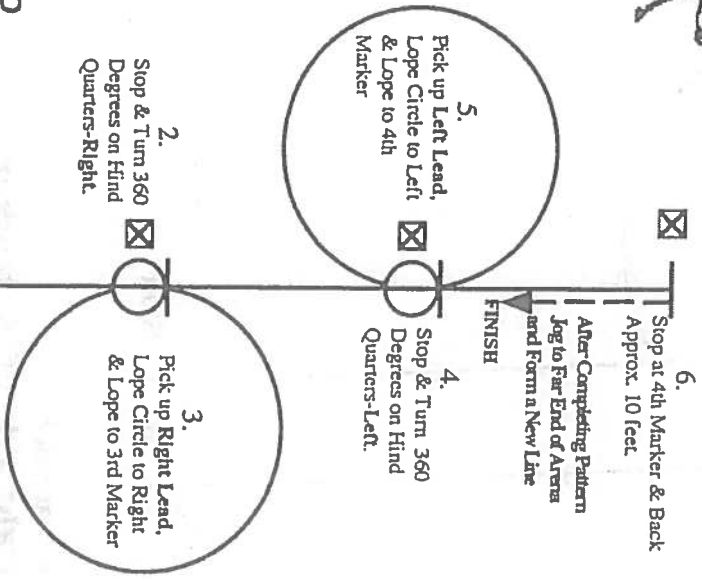
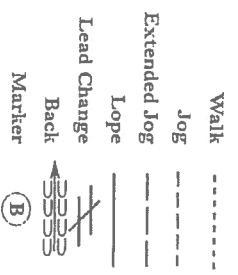

GOOD LUCK!

1. When Signaled, Pick Left Lead and Lope to 2nd Marker.
 2. Stop & Turn 360 Degrees on Hind Quarters-Right.
 3. Pick up Right Lead, Lope Circle to Right & Lope to 3rd Marker.
 4. Stop & Turn 360 Degrees on Hind Quarters-Left.
 5. Pick up Left Lead, Lope Circle to Left & Lope to 4th Marker.
 6. Stop at 4th Marker & Back A approx. 10 feet.
- START Be Waiting At 1st Marker

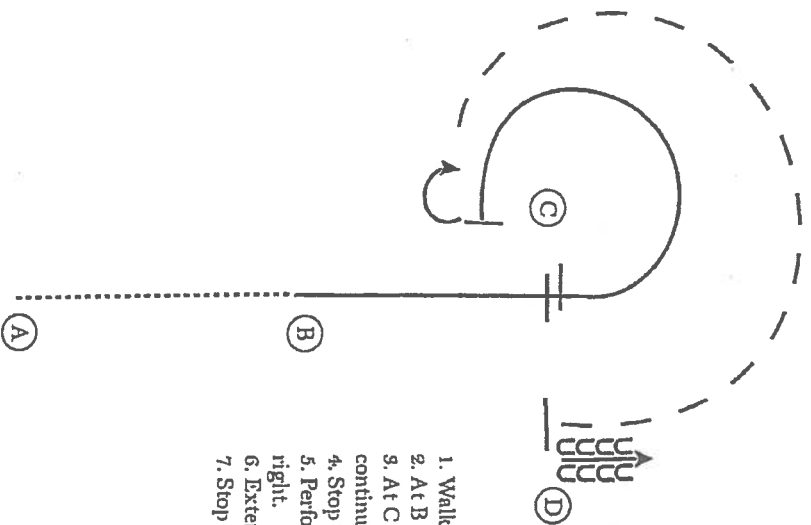

1. Walk A to B.
2. At B lope on the right lead to C.
3. At C perform a lead change and continue on the left lead around C.
4. Stop at C.
5. Perform a 180 degree turn to the right.
6. Extend the jog around C.
7. Stop at D and back 4 steps.

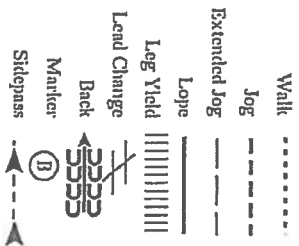

WALK TROT PATTERNS

Walk Trot Pattern

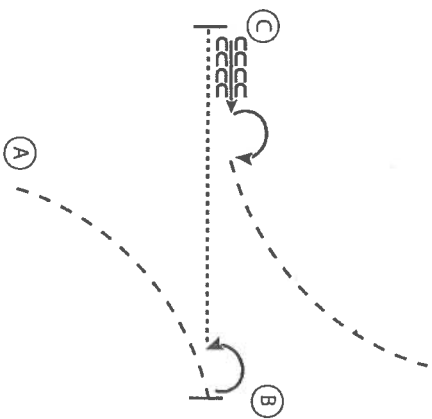

1. Jog a quarter circle from A to B
2. Stop at B and perform a 180 degree turn to the left on the hindquarters
3. Walk to C
4. At C stop and back 4 steps
5. Perform a 180 degree turn to the right
6. Jog a quarter circle to exit

Follow the instructions of the ring steward.

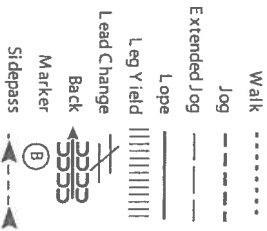

WALK TROT PATTERNS

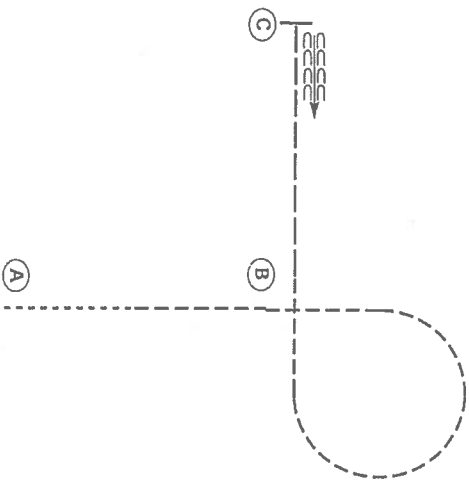

- Be ready at A.
1. Walk from A 1/2 way to B.
 2. Jog the rest of the way to B.
 3. Jog a circle to the right.
 4. Extend the jog from B to C.
 5. Stop at C and back one horse length.

Follow the instructions of the ring steward.

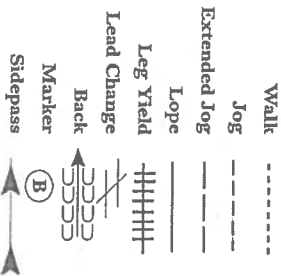

WALK TROT PATTERNS

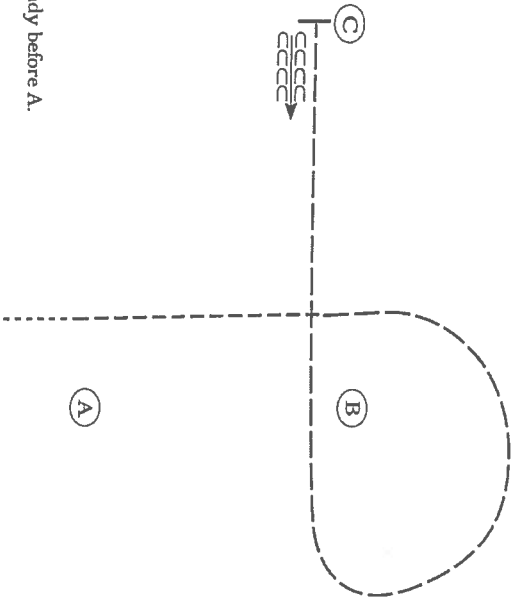

- Be ready before A.
1. Walk to A.
 2. Jog from A to B.
 3. Extend the jog around B and to C.
 4. Stop at C and back approximately one horse length.
- Follow the instructions of your ring steward.

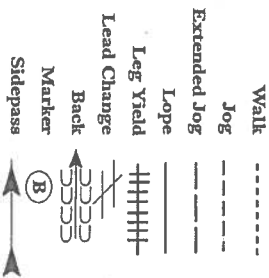

WALK TROT PATTERNS

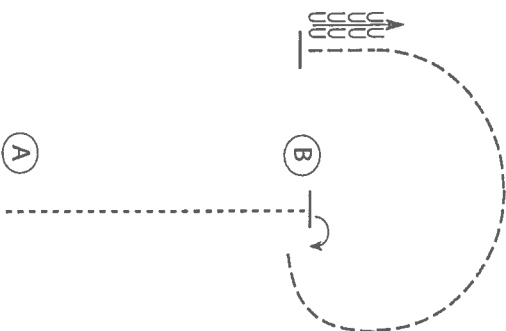

- Be ready at A.
1. Walk from A to B
 2. At B stop and perform a 90 degree turn to the right on the haunches
 3. Jog in a circular pattern until even with B as diagrammed
 4. Stop even with B and back approximately one horse length
- Follow the instructions of the ring steward.

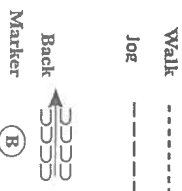

WALK TROT PATTERNS

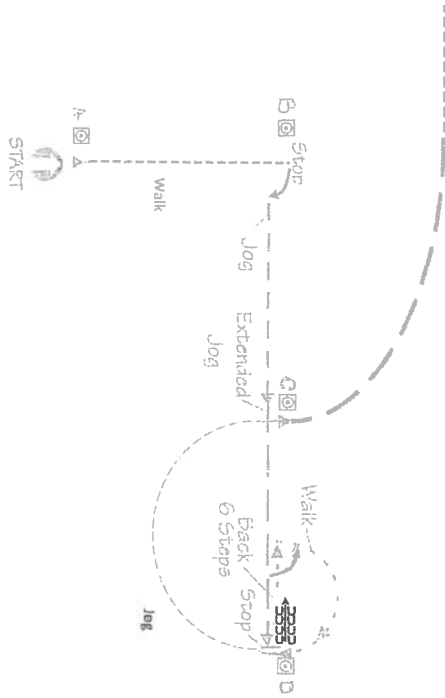

- Be ready at cone A
1. When acknowledged by Judge, walk to cone B
 2. Stop and perform a 1/4 turn (90°) right on hindquarters
 3. Jog to C and Extend the jog to D
 4. Stop and back six (6) steps
 5. Perform a 90 degree haunch turn to the left.
 6. Walk a half circle to D.
 7. At cone D, jog a half circle to C as shown
 8. Extend the jog as shown until even with B
 9. Break to walk and
- Follow the instructions of the ring steward



WALK TROT PATTERNS

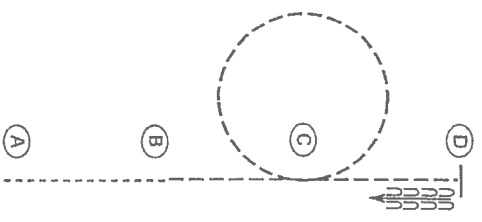

- Be ready at A.
1. Walk from A to B.
 2. Jog to C and circle to the left.
 3. Continue to jog to D.
 4. Stop and D and back one horse length.
- Follow the instructions of the ring steward.

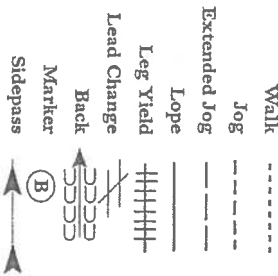

WALK TROT PATTERNS

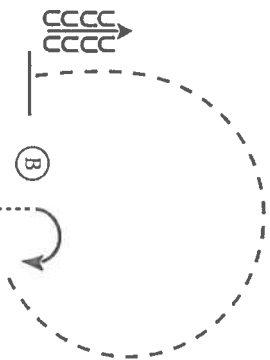

1. Walk A to B
2. At B perform a 90 degree turn to the right
3. Jog a circle around B
4. At B stop and back 4 steps

Follow the instructions of the ring steward.

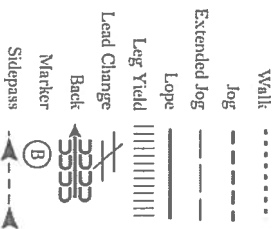

WALK TROT PATTERNS

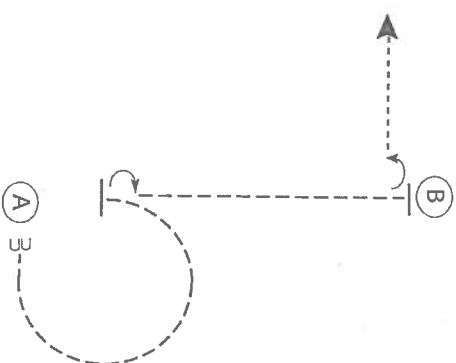

1. Jog a 3/4 circle back toward A.
2. Stop and perform a 180 degree turn to the right.
3. Jog to B.
4. Stop and perform a 90 degree turn to the left and walk off.

Follow the instructions of your ring steward.

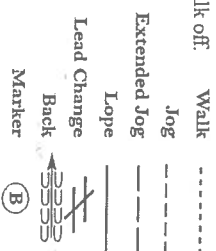

WALK TROT PATTERNS

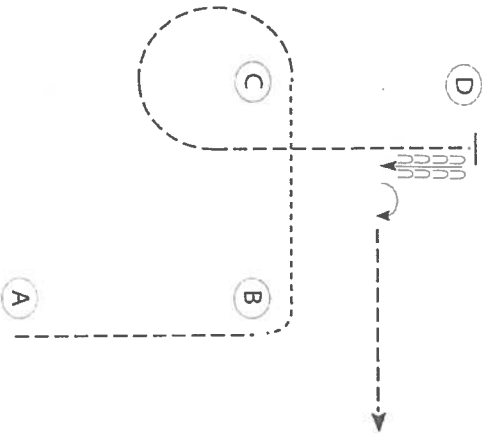

Be ready at A.

1. Jog to B.
2. WALK around B and continue to C at the walk
3. At C: Jog in a circular pattern around C as shown
4. Continue to jog in a straight line to D
5. Stop at D and back a horse length
6. Turn 90 degrees to the right on the hindquarters
7. Jog to line up following the ring steward's instruction

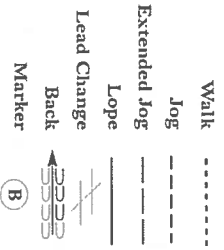

WALK TROT PATTERNS

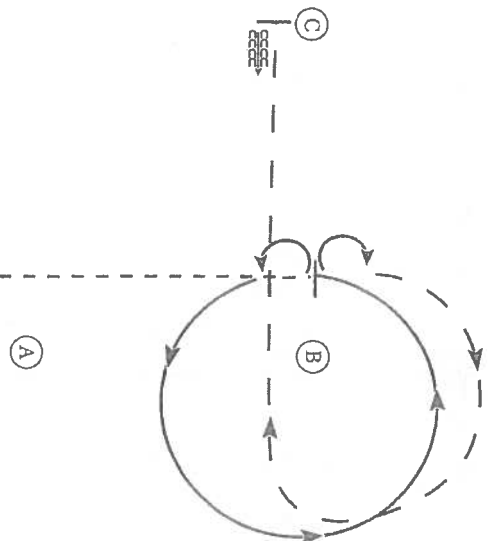

Be ready at A

1. Walk A to B
2. Stop at B and perform a 180 degree turn to the left on hindquarters.
3. Jog a circle to the left around to B.
4. Stop at B and perform a 180 degree turn to the right on the hindquarters.
5. Extended Jog around B and to C.
6. Stop at C and back one horse length, exit the pattern at a walk.

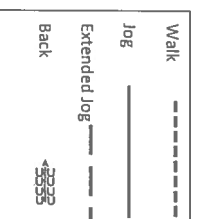

Follow the instructions of your ring steward.

WALK TROT PATTERNS

Be ready at A

1. Jog A to B
2. At B continue the jog in a circle to the right.
3. At B extend the jog in a circle to the left.
4. At B slow to a jog and jog from B to C.
5. Stop at C and back four (4) steps.

Follow the instructions of the ring steward

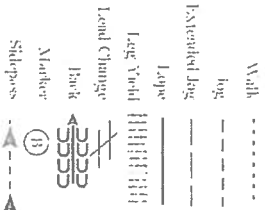
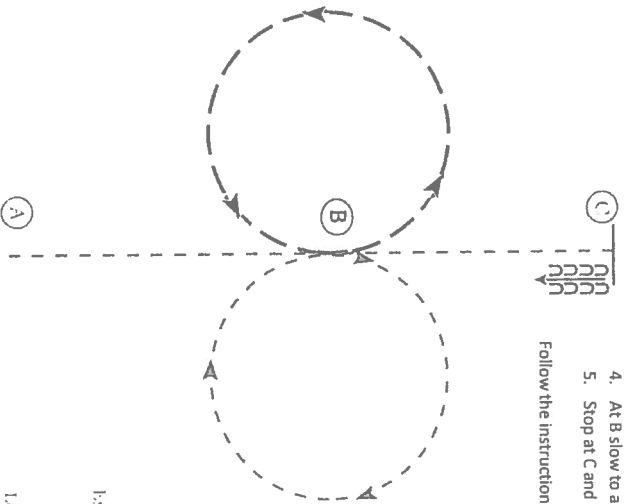

WALK TROT PATTERNS

Be ready at A

1. Walk A to B
2. At B stop and perform a 360 degree turn on hindquarters.
3. Jog to C and continue jogging in a circle to the left around C.
4. Extend the jog to D.
5. At D Stop
6. Back two (2) horse lengths.
7. Jog to line up

Follow the instructions of the ring steward

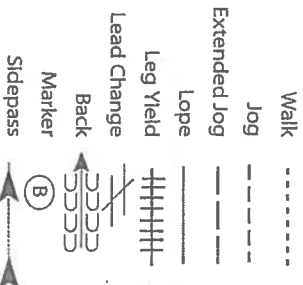
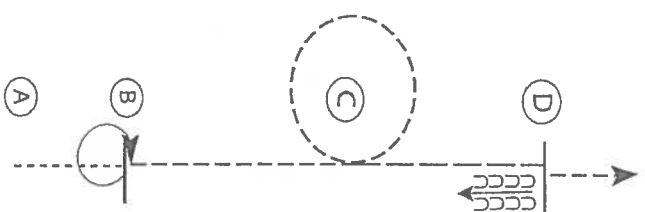

Follow the instructions of the ring steward

WALK TROT PATTERNS

1. Walk from A to B.
2. Jog from B to C.
3. Continue jogging a circle around C to D.
4. Stop at D, back 5 steps.

Follow instructions of ring steward

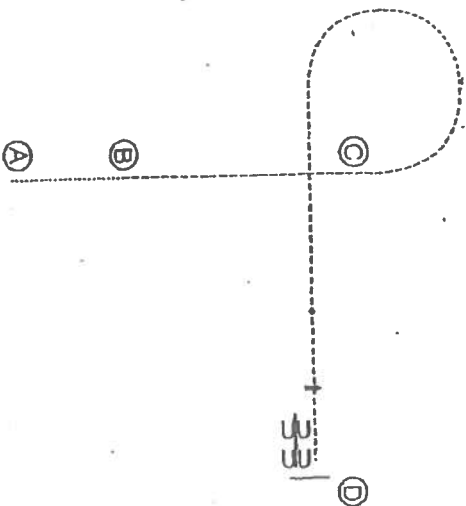

WALK TROT PATTERNS

- Be ready at A.
1. Walk from A to B.
 2. Stop past B and execute a 90 degree turn to the right.
 3. Jog from B around C.
 4. Extend the jog from C to D.
 5. Stop at D and back one horse length.
- Please exit at a jog.
- Follow instructions of ring steward

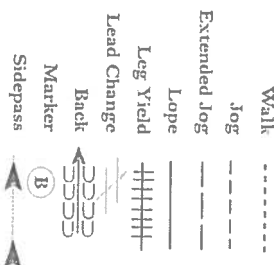
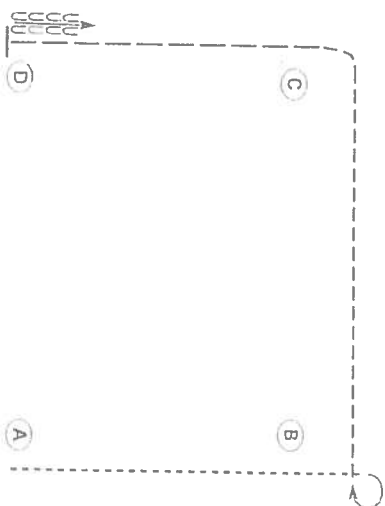

WALK TROT PATTERNS

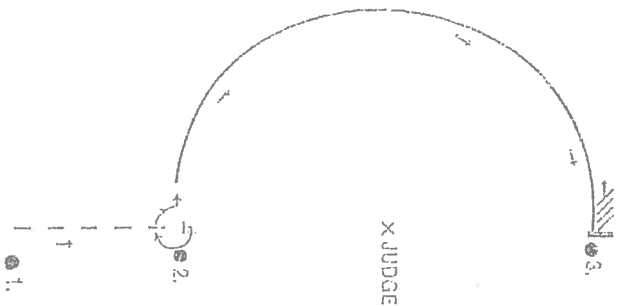

1. At first marker, walk
2. At second marker, stop, and do a 3/4 spin to the right
3. Jog a half-circle to the third marker
4. At third marker, stop and back

Follow instructions of ring steward

WALK TROT PATTERNS

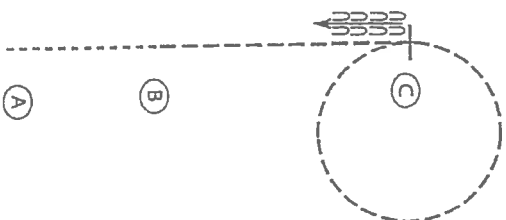

- Be ready at A.
1. Walk from A to B.
 2. Jog from B to C.
 3. Even with C, jog a circle to the right.
 4. Stop at C and back one horse length.

Follow instructions of ring steward

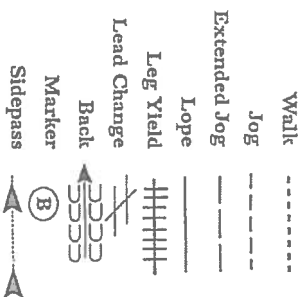

WALK TROT PATTERNS

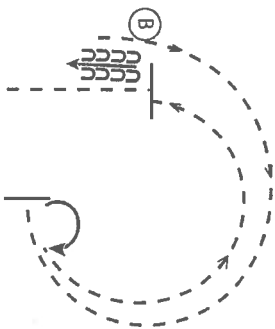

1. Walk to A
 2. Jog A to B
 3. At B stop and back
 4. Jog 3/4 circle to the right
 5. Stop and perform a 180 degree turn to the right on the hindquarter
 6. Jog a circle back to B
 7. Stop at B
- Follow instructions of ring steward

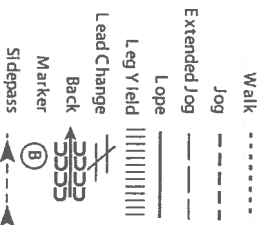

WALK TROT PATTERNS

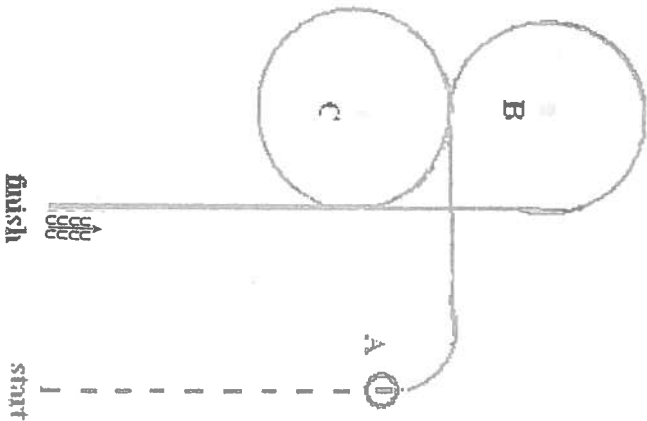

1. Walk to cone A
 2. Pivot 360 haunch turn left
 3. Jog circle around cone C
 4. Jog 3/4 circle around cone B
 5. Continue at jog cone D, stop and back a horse length
 6. Exit to line at a walk
- Follow instructions of ring steward

